



**DIPLOMATIC  
HYDRAULICS**

23 300/104 ED



**S\*-P**  
SEQUENCE VALVE

**U\*-P**  
UNLOADING VALVE

**T\*-P**  
BACKPRESSURE VALVE

**X\*-P**  
BALANCING VALVE

**SERIES 20**

**OPERATING PRINCIPLE**

- The S U T X sequence valves are used for pressure control. They are direct-acting and normally closed.
- They are available in two nominal sizes for flows up to 150 l/min and in four pressure adjustment ranges.
- Opening takes place by means of a pilot pressure that, acting on a small piston, resists the force of the adjustment spring.
- The valve can be easily modified to get any one of the four versions **S**, **U**, **T**, **X**, turning the upper and the bottom covers in order to obtain the X and Y internal connections, as indicated in par. 7. The figure represents the section of a type S valve.

<b>PERFORMANCE RATINGS</b> (measured with mineral oil of viscosity 36 cSt at 50°C)		<b>size 3</b>	<b>size 5</b>
Maximum operating pressure	bar	320	250
Maximum flow rate	l/min	60	150
Ambient temperature range	°C	-20 ÷ +50	
Fluid temperature range	°C	-20 ÷ +80	
Fluid viscosity range	cSt	10 ÷ 400	
Recommended viscosity	cSt	25	
Degree of fluid contamination	According to NAS 1638 class 10		
Mass	kg	5,8	6,7

**HYDRAULIC SYMBOLS**

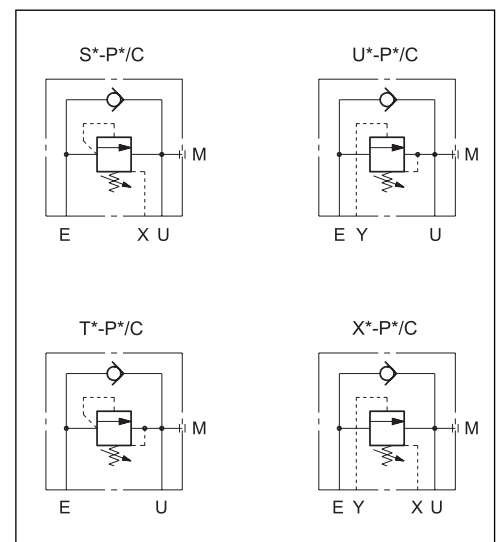



# SUTX-P

## SERIES 20

### 1 - IDENTIFICATION CODE

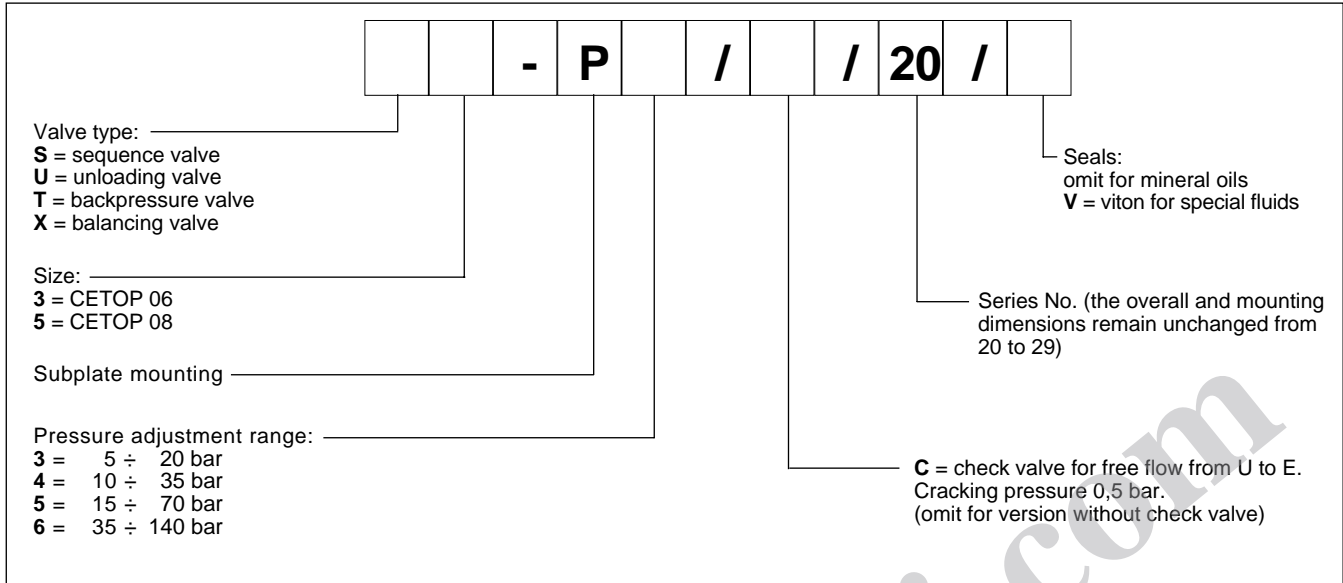

### 2 - CHARACTERISTIC CURVES (values obtained with viscosity of 36 cSt at 50°C)

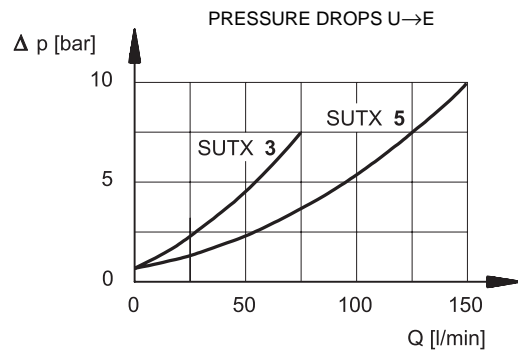
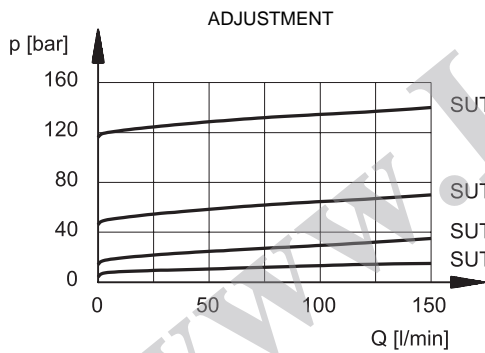

### 3 - HYDRAULIC FLUIDS

Use mineral oil-based hydraulic fluids, with the addition of suitable anti-frothing and anti-oxidizing agents.  
For the use of other types (water glycol, phosphate esters and others), please consult our technical department.



# S U T X - P

## SERIES 20

### 4 - S U T X 3-P OVERALL AND MOUNTING DIMENSIONS

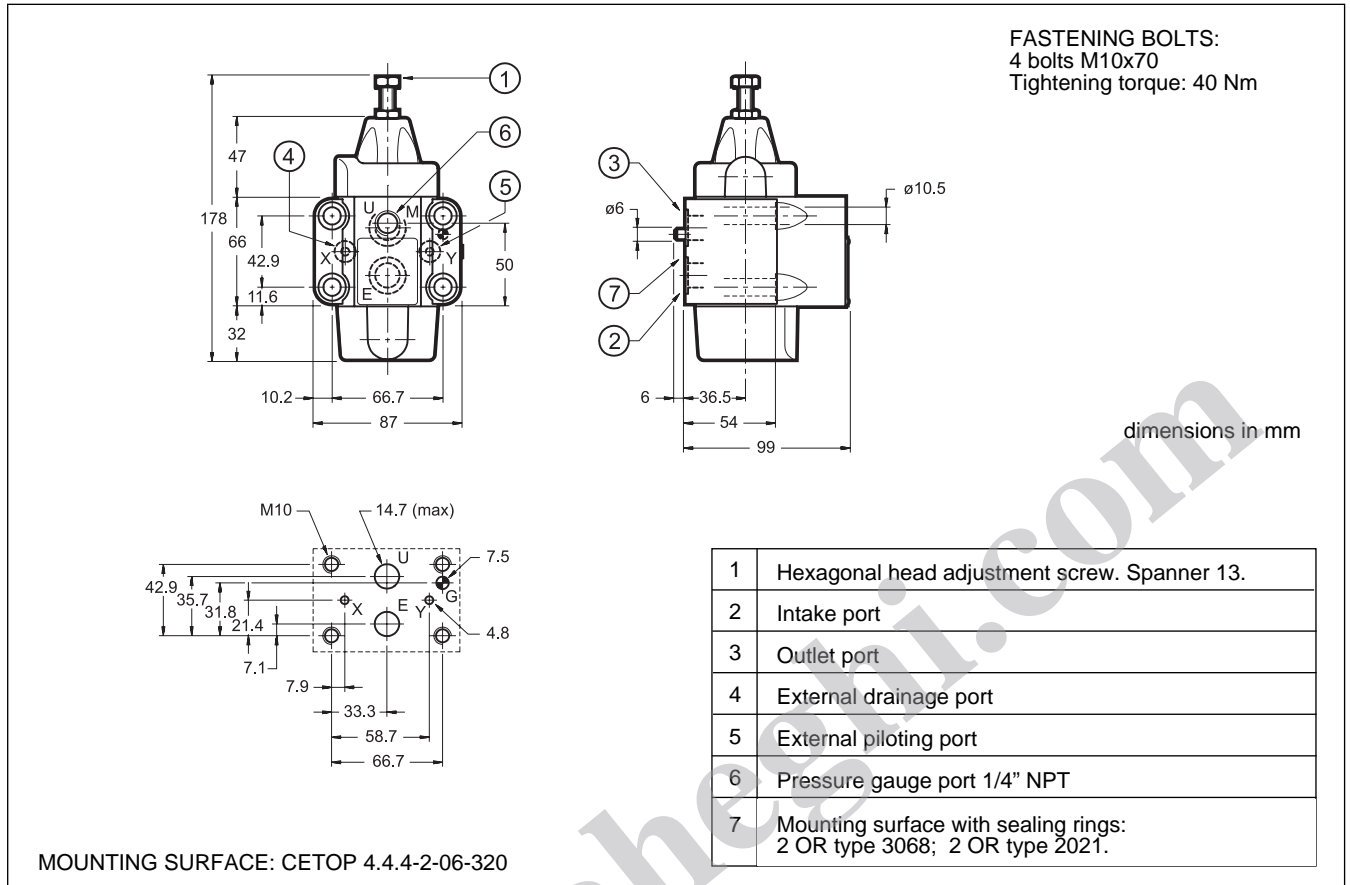

### 5 - S U T X 5-P OVERALL AND MOUNTING DIMENSIONS

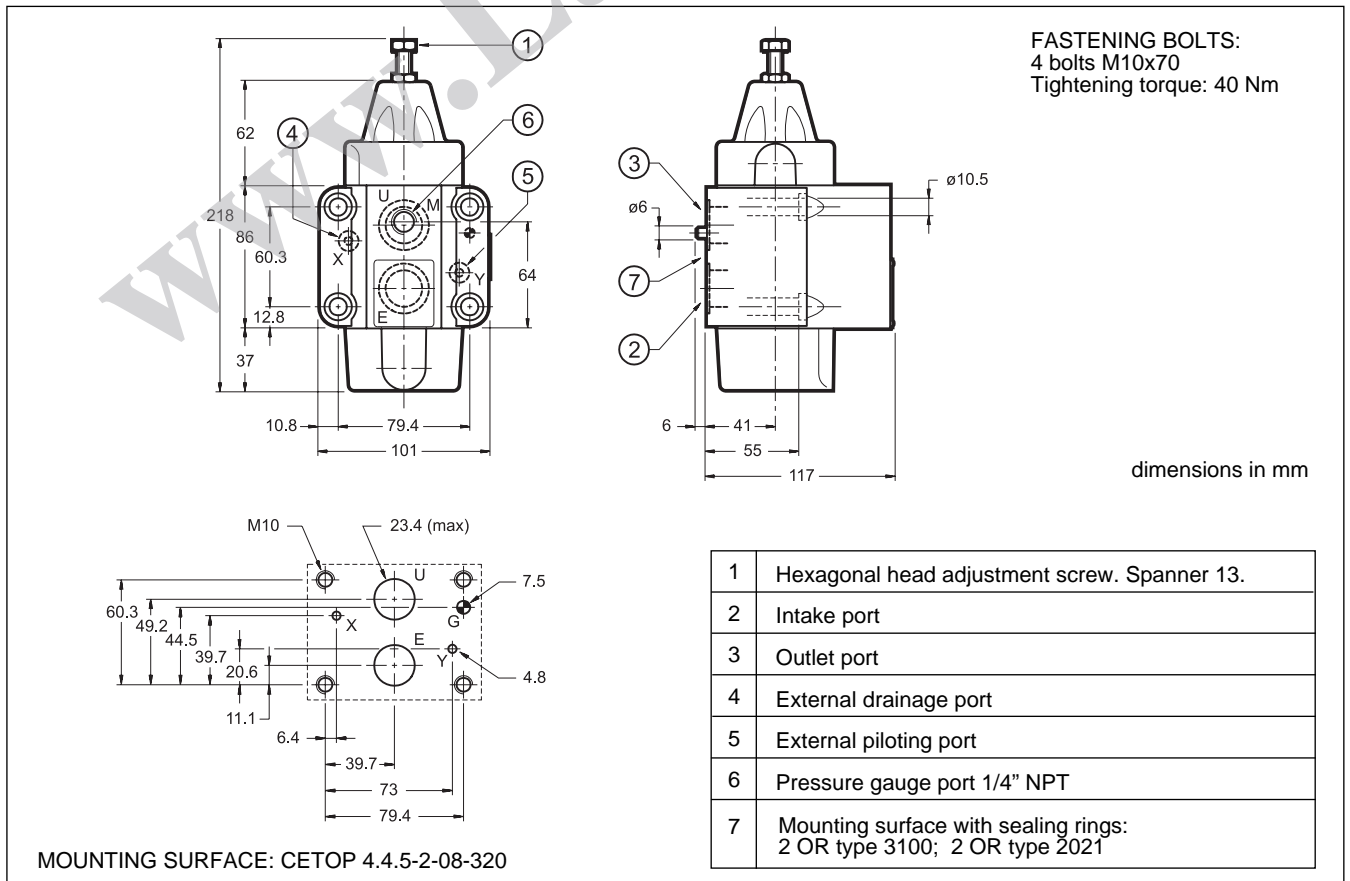



## 6 - APPLICATIONS

**“S”** The type “S” sequence valve is normally used to successively command two or more actuators: when the pressure in the primary circuit reaches the set value on the valve, it opens and allows the fluid to feed the second circuit branch, keeping the pressure in the first branch. The valve remains open until the pressure at the intake falls below the set value; under these conditions, the maximum pressure setting on the first circuit branch will be achieved also at the outlet. It is also used to keep a circuit under pressure when simultaneous supply of various users, requiring the total delivery of the pump, would make the pressure value decrease.

**“U”** This is normally used in automatic circuits (high-low pressure) for unloading the low pressure pump; this occurs when the pressure in the circuit reaches the set value of the valve. In this manner it is possible to utilize the total flow of the two pumps for fast movements at low pressure, with electric power saving, using high pressure only for working movements. Furthermore, it is used to allow quick discharge of the large chamber of a high differential cylinder which the directional valve would not be able to drain; in this case the valve piloting is connected to the small chamber of the cylinder.

**“T”** Normally this is used to create hydraulic resistance (back pressure) to prevent uncontrolled movements, especially in the case of suspended loads. The valve, normally closed, opens only when the set pressure is reached, and thus the descent of the load occurs in a controlled manner and the descending speed depends on the delivery of the pump.

**“X”** This is mainly used for load balancing. The piloting pressure can be taken from any point in the plant. The valve stays closed until the pilot pressure reaches the set value.

## 7 - COVER ORIENTATION FOR THE VARIOUS VERSIONS S, U, T, X

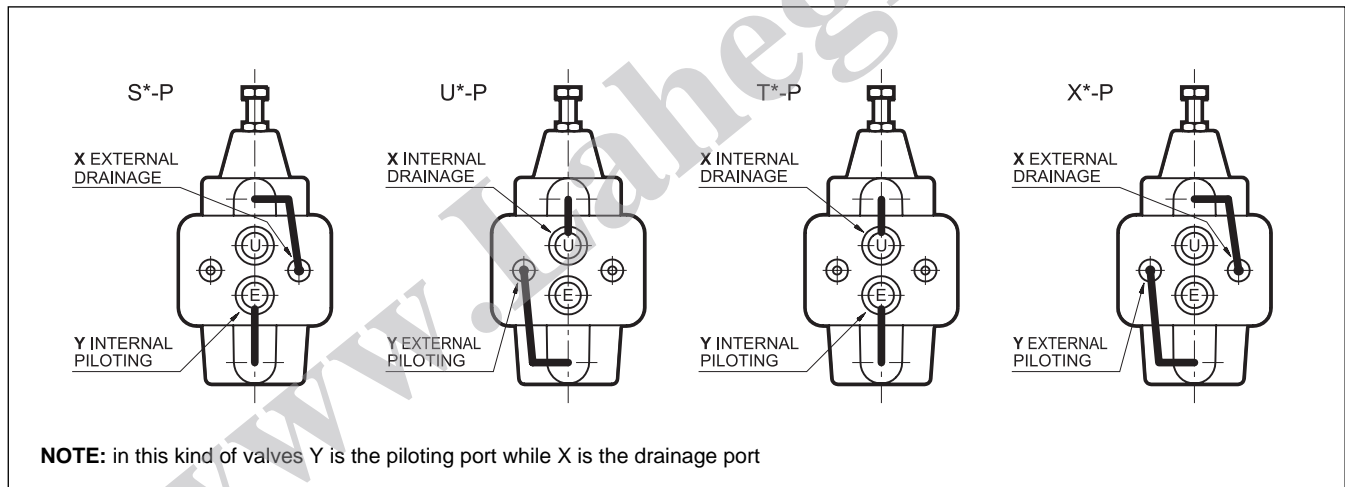

## 7 - SUBPLATES (see catalogue 51 000)

	S U T X 3-P*	S U T X 5-P*
Type	PMSZ3-AI4G with rear ports	PMSZ5-AI5G with rear ports
Port dimensions E, U X, Y	1/2 " BSP 1/4 " BSP	1" BSP 1/4 " BSP

	<p><b>DIPLOMATIC OLEODINAMICA SpA</b>          20025 LEGNANO (MI) - P.le Bozzi, 1 / Via Edison          Tel. 0331/472111 - Fax 0331/548328</p>
--	--